

# DRAFT



Farmington Canal Heritage Trail

Tariffville-Bloomfield Connector



Mapsheet 2

Mapsheet 3

Mapsheet 4

Mapsheet 5

Mapsheet 6

Mapsheet 7

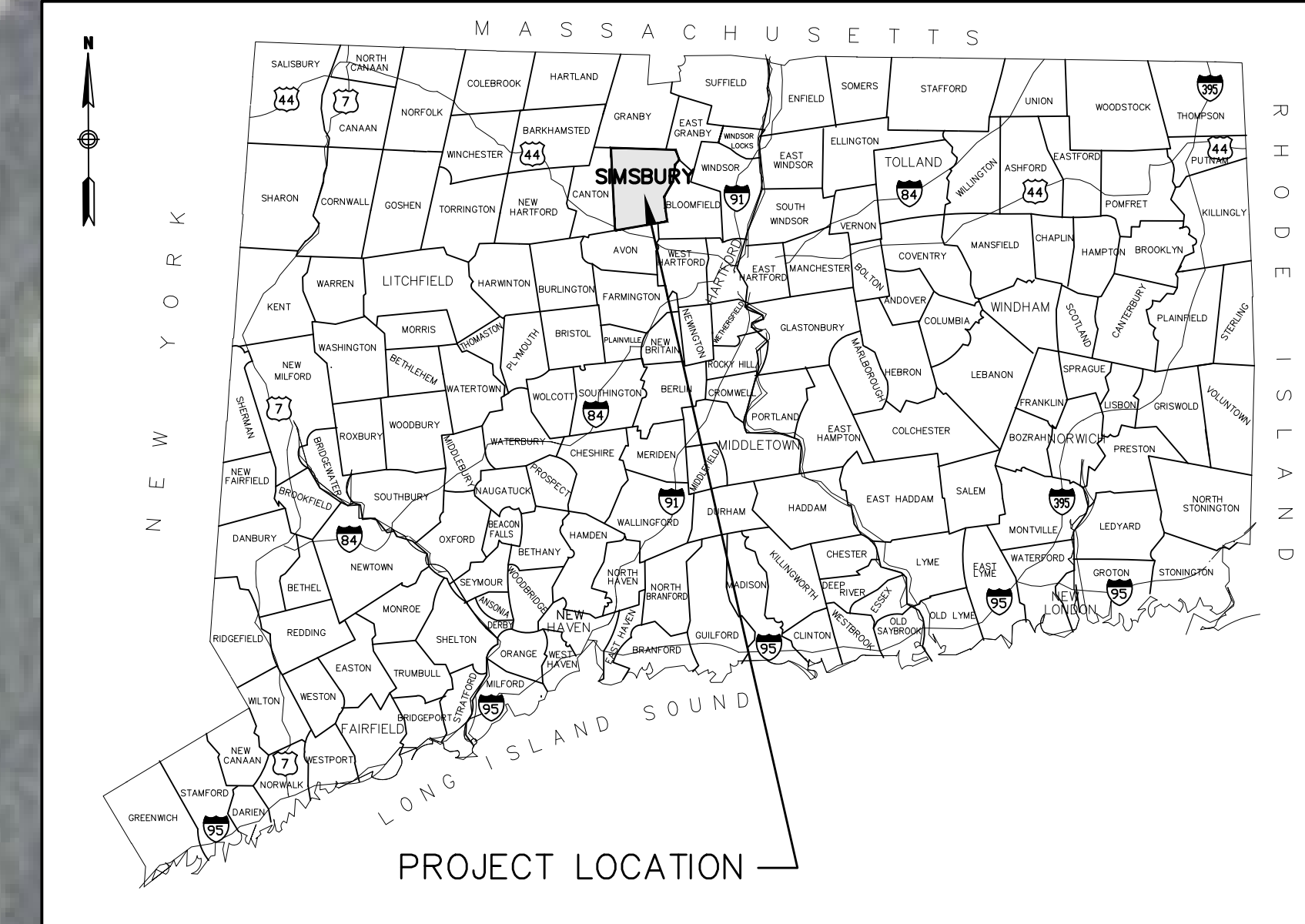
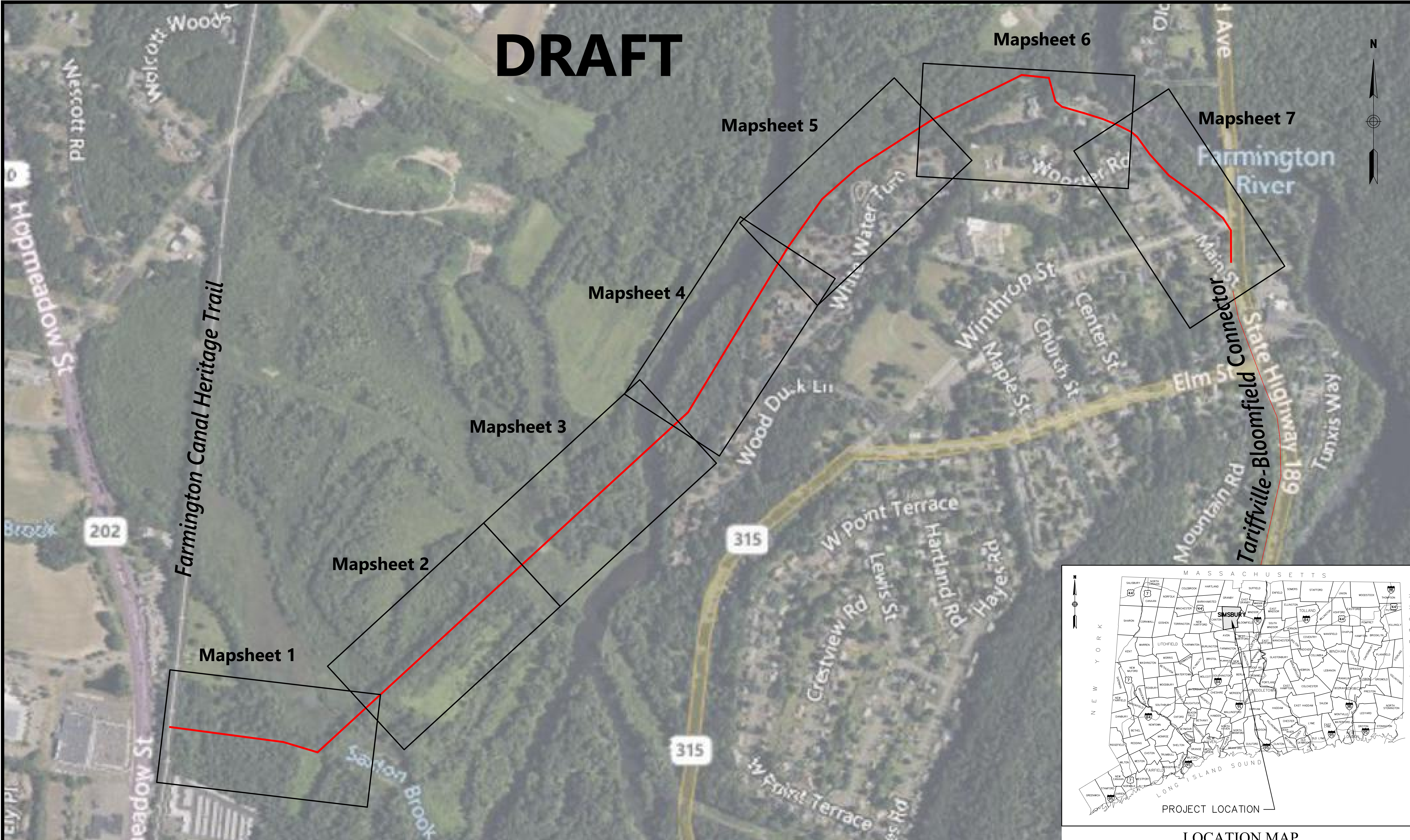

LOCATION MAP

REV.	DATE	DESCRIPTION REVISIONS	SHEET. NO.



DESIGNER:  
DRAFTER:  
CHECKED BY:  
APPROVED BY:

DATE: DECEMBER 13, 2023



PROJECT TITLE:  
**TARIFFVILLE GREENWAY –  
EAST COAST GREENWAY**  
CAPITOL REGION  
**EAST COAST  
GREENWAY STUDY**  
CADD FILENAME: INDEX\_4319400.DWG

TOWN:  
**SIMSBURY, CT**  
DRAWING TITLE:  
**INDEX PLAN**

PROJECT NO.:  
**43194.00**  
DRAWING NO.:  
**IND-01**  
SHEET NO.:

# DRAFT

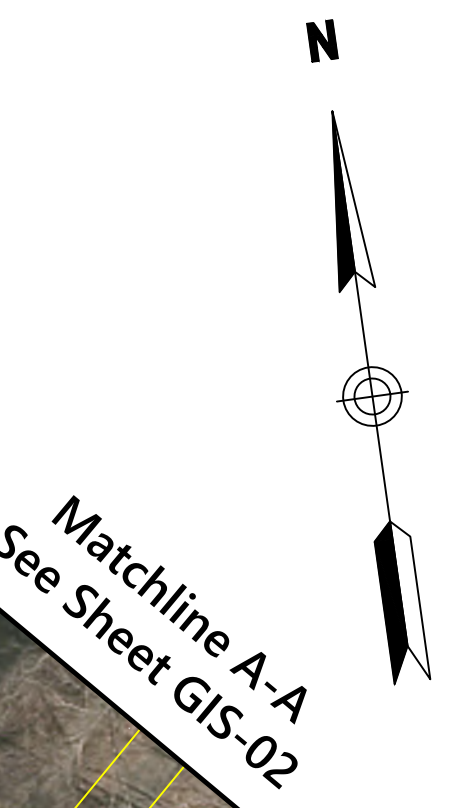
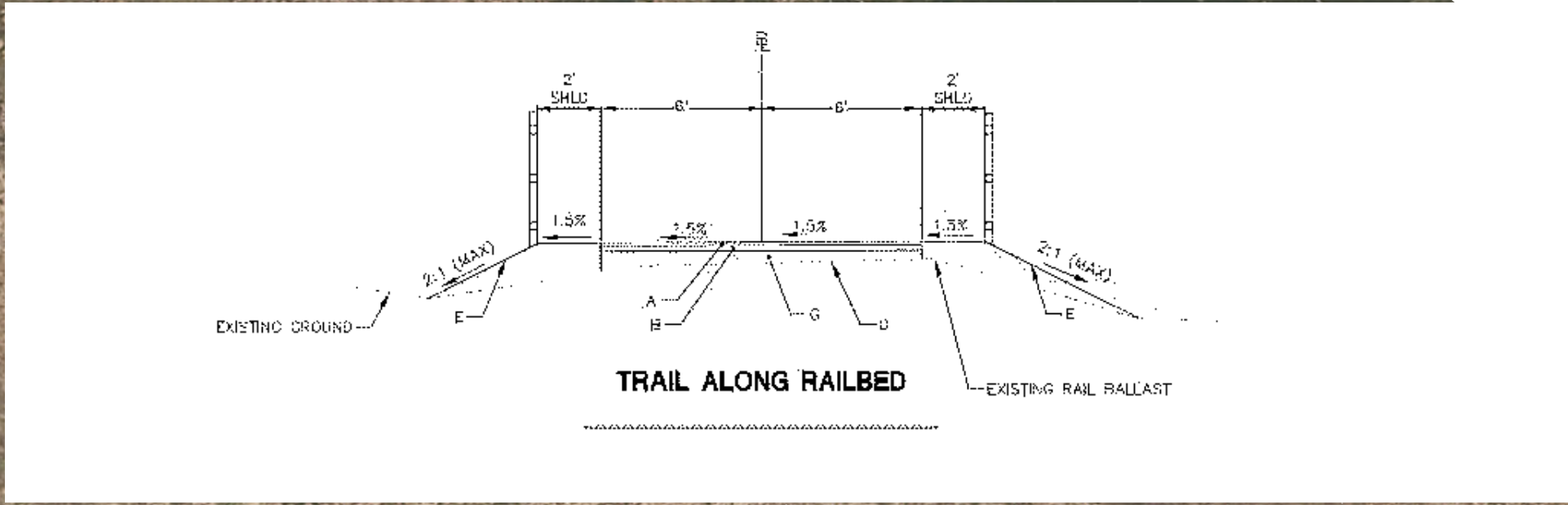

Farmington Canal Heritage Trail

PROPOSED 12' WIDE PAVED TRAIL

PROPOSED 12' WIDE TRAIL ON FORMER RAIL CORRIDOR EMBANKMENT

REV.	DATE	DESCRIPTION REVISIONS	SHEET. NO.



DESIGNER:  
 DRAFTER:  
 CHECKED BY:  
 APPROVED BY:



DATE: DECEMBER, 2023

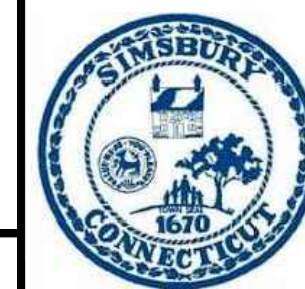

PROJECT TITLE:  
**TARIFFVILLE GREENWAY – EAST COAST GREENWAY**  
 CAPITOL REGION  
**EAST COAST GREENWAY STUDY**  
 CADD FILENAME: GIS\_4319400.DWG

TOWN:  
**SIMSBURY, CT**  
 DRAWING TITLE:  
**PROPOSED TRAIL CONCEPT PLAN**

PROJECT NO.:  
**43194.00**  
 DRAWING NO.:  
**GIS-01**  
 SHEET NO.:

# DRAFT

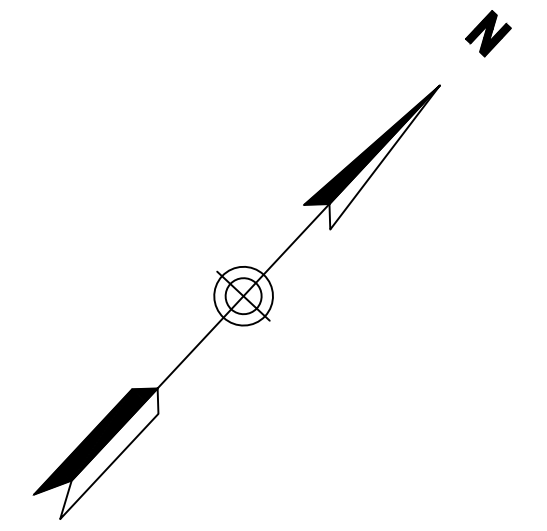

Matchline A-A  
See Sheet GIS-01

Matchline B-B  
See Sheet GIS-03



PROPOSED 12' WIDE TRAIL  
ON FORMER RAIL  
CORRIDOR EMBANKMENT

REV.	DATE	DESCRIPTION REVISIONS	SHEET. NO.



DESIGNER:  
DRAFTER:  
CHECKED BY:  
APPROVED BY:

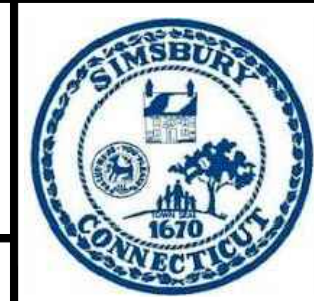

PROJECT TITLE:  
**TARIFFVILLE GREENWAY –  
EAST COAST GREENWAY**  
CAPITOL REGION  
**EAST COAST  
GREENWAY STUDY**  
CADD FILENAME: GIS\_4319400.DWG

TOWN:  
**SIMSBURY, CT**  
DRAWING TITLE:  
**PROPOSED TRAIL  
CONCEPT PLAN**

PROJECT NO.:  
**43194.00**  
DRAWING NO.:  
**GIS-02**  
SHEET NO.:

# DRAFT

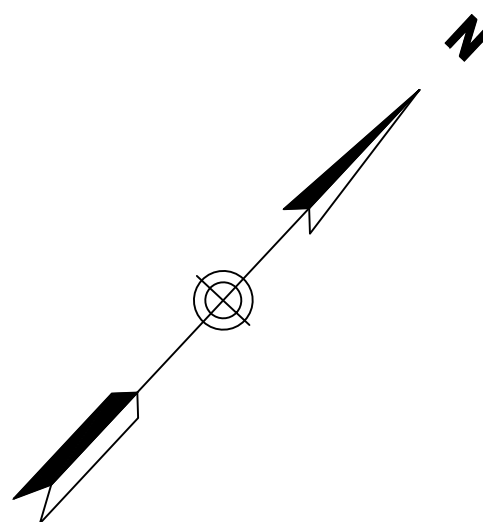

Farmington River

UTILITY EASEMENT WITH HIGH-TENSION POWER LINES

APPROXIMATE LOCATION FOR BRIDGE ABUTMENTS

Matchline B-B  
See Sheet GIS-02

Matchline C-C  
See Sheet GIS-04

PROPOSED 12' WIDE TRAIL ON FORMER RAIL CORRIDOR EMBANKMENT

12' WIDE BOARDWALK SEGMENT OVER WETLANDS

12'-14' WIDE TRAIL BRIDGE

PROPOSED 12' WIDE TRAIL ON FORMER RAIL CORRIDOR EMBANKMENT

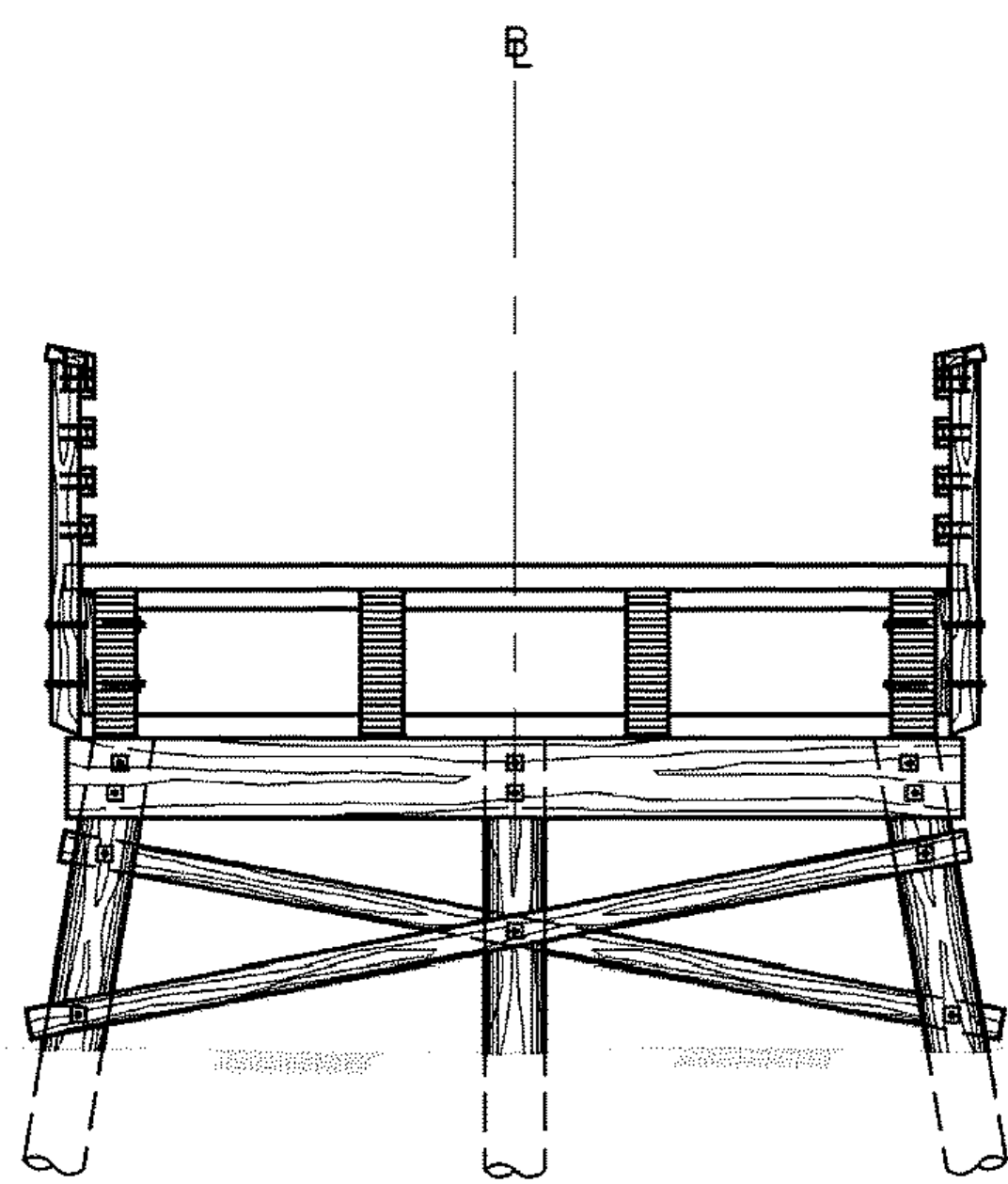

DESIGNER:  
DRAFTER:  
CHECKED BY:  
APPROVED BY:

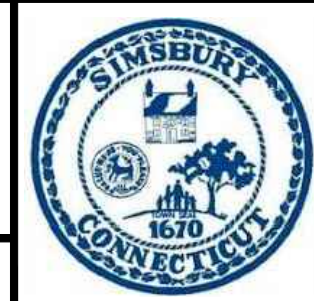

PROJECT TITLE:  
**TARIFFVILLE GREENWAY – EAST COAST GREENWAY**  
CAPITOL REGION  
**EAST COAST GREENWAY STUDY**  
CADD FILENAME: GIS\_4319400.DWG

TOWN:  
**SIMSBURY, CT**  
DRAWING TITLE:  
**PROPOSED TRAIL CONCEPT PLAN**

PROJECT NO.:  
**43194.00**  
DRAWING NO.:  
**GIS-03**  
SHEET NO.:

REV.	DATE	DESCRIPTION REVISIONS	SHEET. NO.

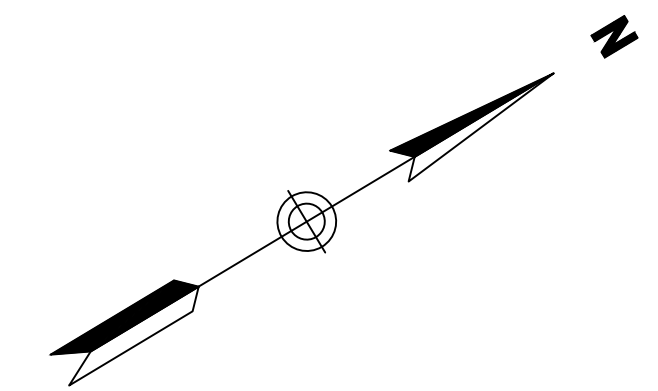

**DRAFT**

Farmington River  
→

Matchline C-C  
See Sheet GIS-03

Matchline D-D  
See Sheet GIS-05

PROPOSED 12' WIDE TRAIL ON FORMER RAIL CORRIDOR EMBANKMENT

POTENTIAL ROUTE ALTERNATIVE FOR 12' WIDE TRAIL CLOSER TO THE EDGE OF THE RIVER

POTENTIAL 12' WIDE TRAIL ROUTE ALTERNATIVE UTILIZING THE FORMER RAIL CORRIDOR EMBANKMENT

CONDO STRUCTURE AT 6 WHITE WATER TURN (~20' FROM TOP OF THE ADJACENT RIVERBANK)

White Water Turn

REV.	DATE	DESCRIPTION REVISIONS	SHEET. NO.



DESIGNER:  
DRAFTER:  
CHECKED BY:  
APPROVED BY:

DATE: DECEMBER, 2023

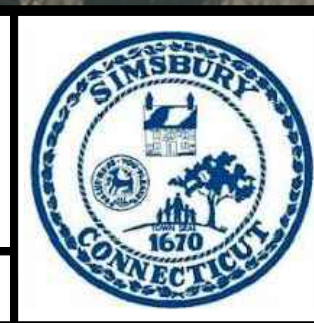

PROJECT TITLE:  
**TARIFFVILLE GREENWAY – EAST COAST GREENWAY**  
CAPITOL REGION  
**EAST COAST GREENWAY STUDY**  
CADD FILENAME: GIS\_4319400.DWG

TOWN:  
**SIMSBURY, CT**  
DRAWING TITLE:  
**PROPOSED TRAIL CONCEPT PLAN**

PROJECT NO.:  
**43194.00**  
DRAWING NO.:  
**GIS-04**  
SHEET NO.:

# DRAFT

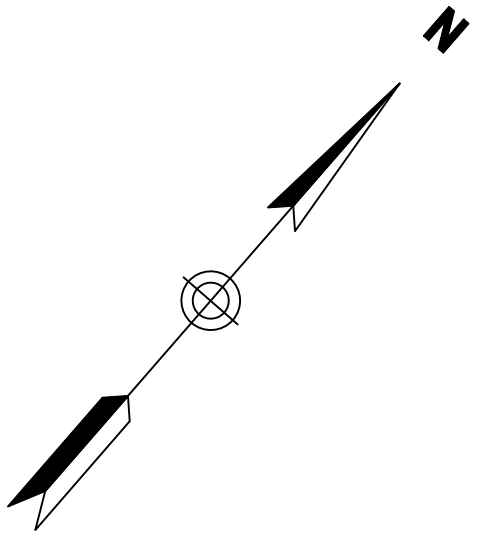

Farmington River

PROPOSED TRAIL CROSSING EXISTING SEWER LINE

12' WIDE TRAIL ALONG FORMER RAIL CORRIDOR  
FINAL TRAIL ALIGNMENT TO BE DETERMINED AFTER  
ADDITIONAL STUDY AND OUTREACH

Matchline D-D  
See Sheet GIS-04

Matchline E-E  
See Sheet GIS-06

White Water Turn

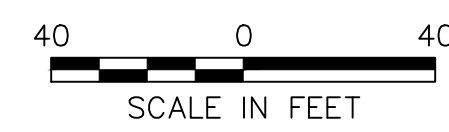

DESIGNER:  
DRAFTER:  
CHECKED BY:  
APPROVED BY:



DATE: DECEMBER, 2023

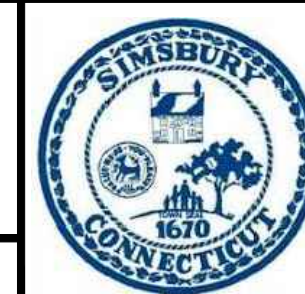

PROJECT TITLE:  
**TARIFFVILLE GREENWAY –  
EAST COAST GREENWAY**  
CAPITOL REGION  
**EAST COAST  
GREENWAY STUDY**  
CADD FILENAME: GIS\_4319400.DWG

TOWN:  
**SIMSBURY, CT**  
DRAWING TITLE:  
**PROPOSED TRAIL  
CONCEPT PLAN**

PROJECT NO.:  
**43194.00**  
DRAWING NO.:  
**GIS-05**  
SHEET NO.:

REV.	DATE	DESCRIPTION REVISIONS	SHEET. NO.

# DRAFT

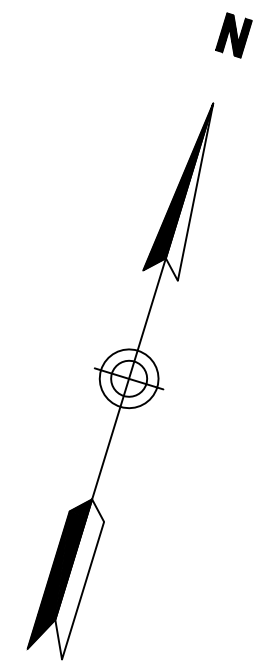

PRIMARY TRAIL  
ACCESS POINT TO  
TARIFFVILLE PARK

Tariffville Park

PROPOSED 12' WIDE TRAIL  
ON FORMER RAIL  
CORRIDOR EMBANKMENT

INSTALL CONCRETE  
SIDEWALK RAMP

700' SPUR TRAIL TO TARIFFVILLE  
ELEMENTARY SCHOOL

INSTALL CONCRETE  
SIDEWALK RAMP

5' WIDE CONCRETE  
SIDEWALK

Farmington River

Main Street Ext.

SHARED USE ROADWAY  
WITH BICYCLE SHARED  
LANE MARKINGS

Matchline F-F  
See Sheet GIS-07



DESIGNER:  
DRAFTER:  
CHECKED BY:  
APPROVED BY:



DATE: DECEMBER, 2023

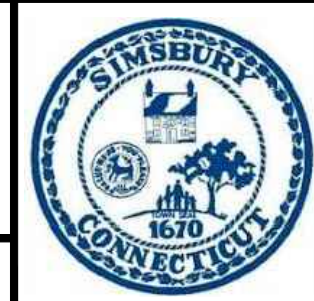

PROJECT TITLE:  
**TARIFFVILLE GREENWAY –  
EAST COAST GREENWAY**  
CAPITOL REGION  
**EAST COAST  
GREENWAY STUDY**  
CADD FILENAME: GIS\_4319400.DWG

TOWN:  
**SIMSBURY, CT**  
DRAWING TITLE:  
**PROPOSED TRAIL  
CONCEPT PLAN**

PROJECT NO.:  
**43194.00**  
DRAWING NO.:  
**GIS-06**  
SHEET NO.:

REV.	DATE	DESCRIPTION REVISIONS	SHEET. NO.

# DRAFT

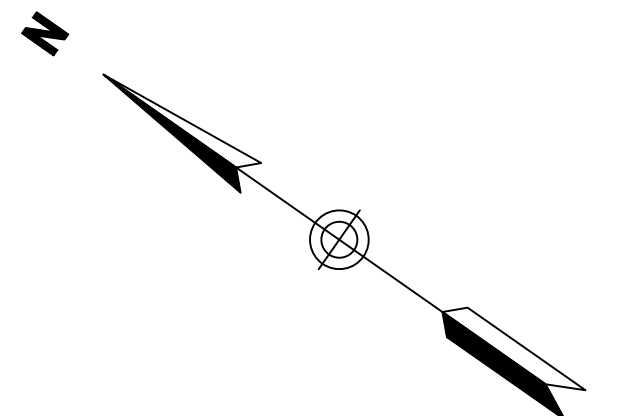
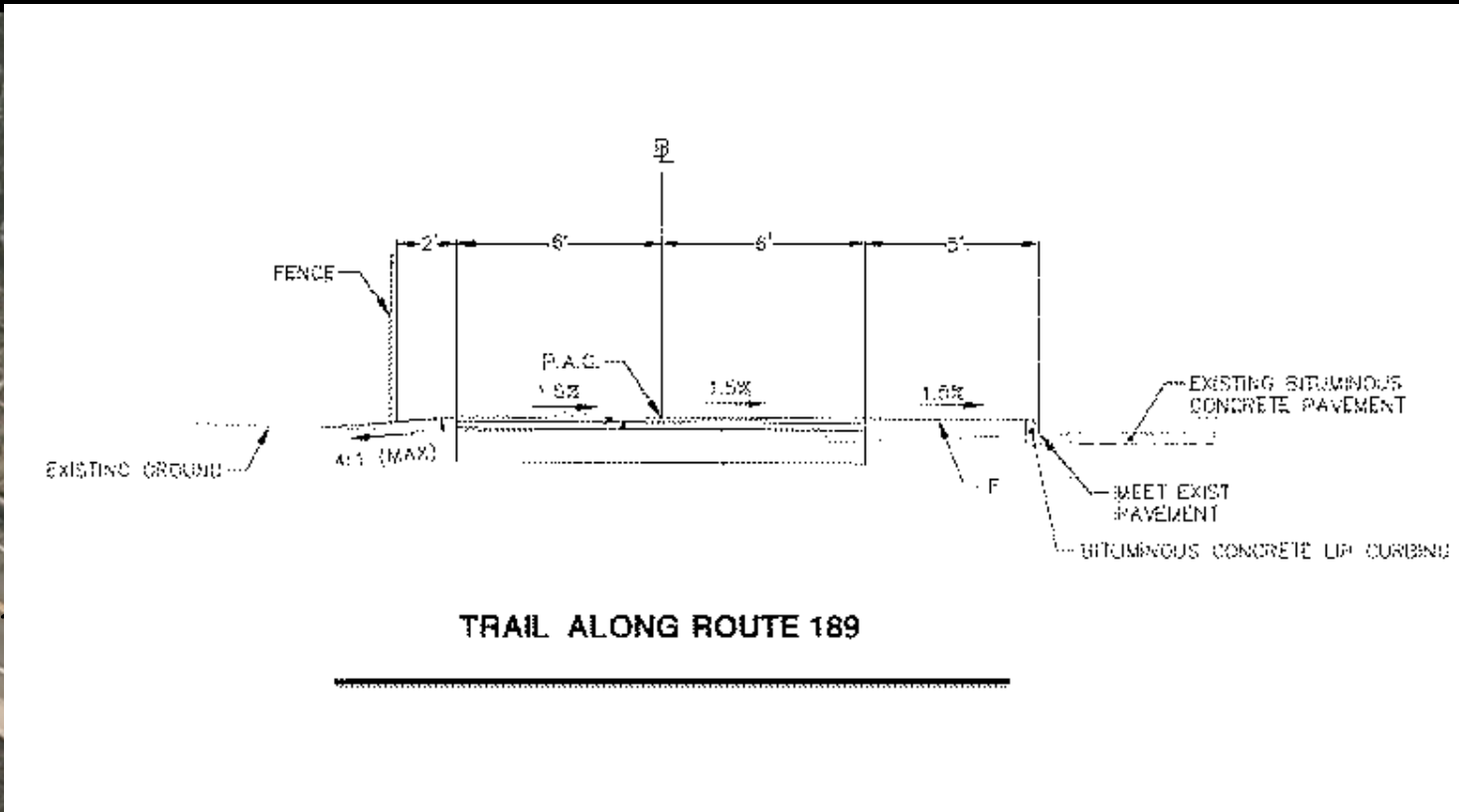

Farmington River

CT-189

WIDEN EXISTING CROSSWALK TO 12 FEET TO ACCOMMODATE TRAIL

PROJECT LIMIT AT CROSSWALK

EXISTING TARIFFVILLE-BLOOMFIELD CONNECTOR TRAIL

PROPOSED 5' WIDE SIDEWALK

INSTALL CONCRETE RAMP

CONNECT TO EXISTING SIDEWALK

PROPOSED 12' WIDE TRAIL

Main Street

Red Hill Road

Winthrop Street

Rooster Road

Matchline F-F  
See Sheet GIS-06



DESIGNER:  
DRAFTER:  
CHECKED BY:  
APPROVED BY:

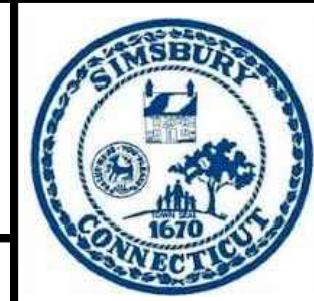

PROJECT TITLE:  
**TARIFFVILLE GREENWAY - EAST COAST GREENWAY**  
CAPITOL REGION  
**EAST COAST GREENWAY STUDY**  
CADD FILENAME: GIS\_4319400.DWG

TOWN:  
**SIMSBURY, CT**  
DRAWING TITLE:  
**PROPOSED TRAIL CONCEPT PLAN**

PROJECT NO.:  
**43194.00**  
DRAWING NO.:  
**GIS-07**  
SHEET NO.:

REV.	DATE	DESCRIPTION REVISIONS	SHEET. NO.